



NEPTUNE X-PRO FULL INVERTER POOL PUMP



INSTALLATION GUIDE AND USER MANUAL



THANK YOU FOR PURCHASING A NEPTUNE FULL INVERTER POOL PUMP.
Please read the manual thoroughly before installing or using the product.
Keep this manual for future reference.

TABLE OF CONTENTS

	Page
SECTION 1: IMPORTANT WARNINGS AND SAFETY INFORMATION	4
SECTION 2: PACKAGING CONTENTS	5
SECTION 3: PRODUCT SPECIFICATIONS	5-6
3.1: PRODUCT DIMENSIONS	5
3.2: TECHNICAL DATA	6
3.3: OPERATING CONDITIONS	6
SECTION 4: INSTALLATION	6-7
4.1: PUMP LOCATION	6
4.2: PLUMBING THE POOL PUMP	7
4.3: VALVES AND FITTINGS	7
SECTION 5: TOUCHPAD OVERVIEW	8
SECTION 6: START-UP AND OPERATION OF THE PUMP	8-13
6.1: PRE-STARTUP INSPECTION	8
6.2: STARTUP	8
6.3: SELF-PRIMING	9
6.4: SELF-CHECKING	9
6.5: PUMP RUNNING	9
6.6: BACKWASH	9
6.7: MANUAL INVERTER MODE	9-10
6.8: AUTO INVERTER MODE	10
6.9: SELF LEARNING	10
6.10: TIMER MODE	11
6.11: SKIMMER MODE	11-12
6.12: SPEED LIMIT	12
6.13: PARAMETER SETTINGS	13
SECTION 7: EXTERNAL CONTROLLER (OPTIONAL)	14-15
SECTION 8: MAINTENANCE	15
SECTION 9: PROTECTION MANAGEMENT	15
9.1: HIGH TEMPERATURE WARNING AND SPEED REDUCTION	15
9.2: UNDER-VOLTAGE PROTECTION	15
SECTION 10: WIFI OPERATION	16-22
10.1: APP DOWNLOAD AND ACCOUNT REGISTRATION	16-17
10.2: CREATE A HOME	17
10.3: APP PAIRING VIA WIFI AND BLUETOOTH	18
10.4: APP PAIRING VIA WIFI ONLY	19
10.5: APP OPERATION – AUTO INVERTER MODE	20
10.6: APP OPERATION – MANUAL INVERTER MODE	20
10.7: APP OPERATION – SETTING THE TIMER	21
10.8: APP OPERATION – SHARING DEVICES WITH FAMILY MEMBERS	22
SECTION 11: TROUBLESHOOTING	23-24
SECTION 12: DISPOSAL	25
SECTION 13: SCHEMATICS	25-26
SECTION 14: WARRANTY AND PRODUCT REGISTRATION	27

SECTION 1: IMPORTANT WARNINGS AND SAFETY INFORMATION



This manual contains important information about the installation, operation, and safe use of this product. This information should be given to the owner and/or operator of the pool pump. When installing and using the pool pump, basic safety precautions should always be followed. Failure to follow safety warnings and instructions in this manual can result in serious injury and/or damage to your equipment. Read and follow all warning notices and instructions which are included in this manual.

GENERAL WARNINGS

- Read the instructions before installing and using the pool pump.
- Failure to follow these instructions and comply with all applicable codes may cause serious bodily injury and/or property damage and will void the warranty.
- Installers/operators must follow manufacturer's instructions and keep in compliance with national or local standards for installation. Under no circumstances will the manufacturer be held responsible for any outcome incurred by failure to comply with applicable standards or local regulations.
- IEC: This appliance is not intended for use by persons (including children) with reduced physical, sensory or mental capabilities, or lack of experience and knowledge, unless they have been given supervision or instruction concerning the use of this product by a person responsible for their safety.
- Children should be supervised to ensure that they do not play with this product.
- EN/UKCA: This product can be used by children aged from 8 years and above and persons with reduced physical, sensory or mental capabilities or lack of experience and knowledge if they have been given supervision or instruction concerning the use of this product in a safe way and understand the hazards involved. Children shall not play with this product. Cleaning and maintenance shall not be conducted by children without supervision.
- If the supply cord is damaged, it must be replaced by the manufacturer, its service agent or similarly qualified persons in order to avoid a hazard.
- The pump power must be supplied through a residual current device (RCD) with a rated residual operating current ≤ 30 mA.
- Always comply with national and local electrical codes and standards.
- Risk of electrical shock. Connect only to a branch circuit protected by a ground-fault circuit interrupter (GFCI). Contact a professionally trained and qualified electrician if you cannot verify that the circuit is protected by a GFCI.
- To prevent the risk of electrical shock, please connect the ground wire on the motor (green/yellow) to the grounding system.
- This pump is for use with permanently installed in-ground or above-ground swimming pools and may also be used with hot tubs and spas with a water temperature under 50°C. Due to the fixed installation method, this pump is not suggested to be used on above-ground pools that can be readily disassembled for storage.
- This pump is not submersible.
- Never open the inside of the drive motor enclosure.
- Fill the pump with water before starting. Do not run the pump dry. In case of dry run, mechanical seal will be damaged and the pump will start leaking. This will void your warranty.
- Before servicing the pump, switch power OFF to the pump by disconnecting the main circuit to the pump and release all pressure from pump and piping system.
- Never tighten or loosen screws while the pump is operating.
- Ensure that the inlet and outlet of the pump are not blocked by foreign matter.
- This product contains electrical equipment. Dispose of the product in accordance with local regulations.
- Use only genuine replacement parts supplied by the manufacturer for service and repair.

DISCLAIMER

Information in this manual is intended to provide general information on a particular subject(s) in good faith and is not an exhaustive treatment of such subject(s). Its use is beyond the control of the author, contributor, publishers, and distributors and should not be relied upon without consulting your local Professional for comprehensive advice. This manual includes subject(s) that should only be performed by or under the direction and advice of your local Professional and under no circumstances should the manual be used as a substitute for such professionals. No representations or warranties are made that the content, advice, and recommendations in this manual are current, free from errors or omissions, or appropriate for the user's circumstances or abilities. No liability is accepted for any loss suffered as a result of any user's reliance on such content. All information in this document is subject to change at any time without notice.



SECTION 2: PACKAGING CONTENTS

The following items are included in the packaging of the pool pump. Please contact your authorised dealer if any items are damaged or missing.

Inverter Pool Pump x 1

User Manual x 1

Unions x 2

RS485 Communication Cable x 1

Lid Loosening Tool x 1

SECTION 3: PRODUCT SPECIFICATIONS

3.1: PRODUCT DIMENSIONS

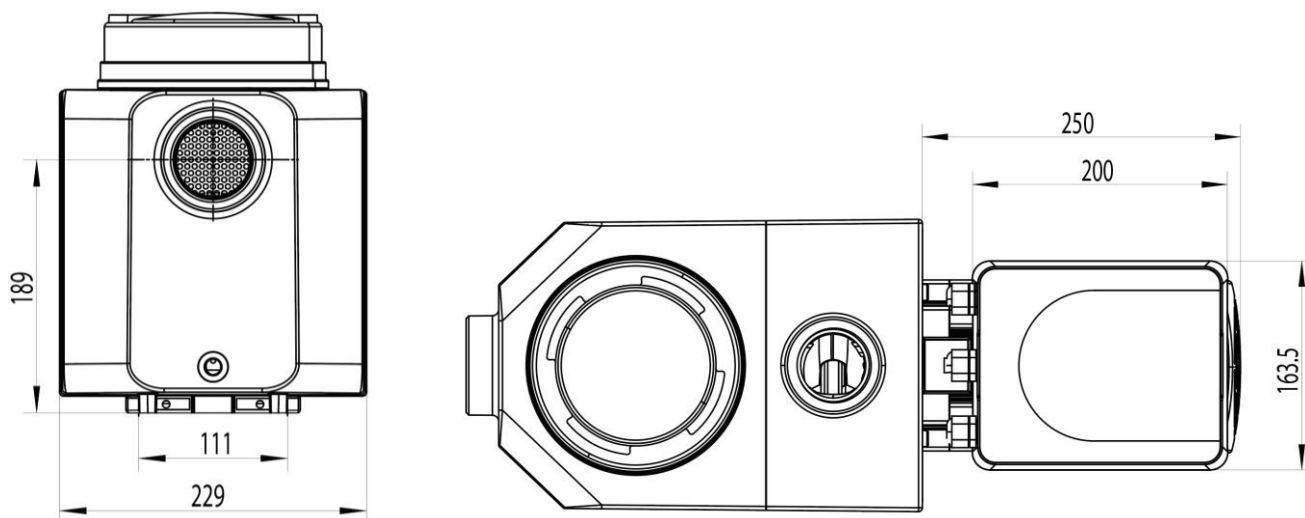
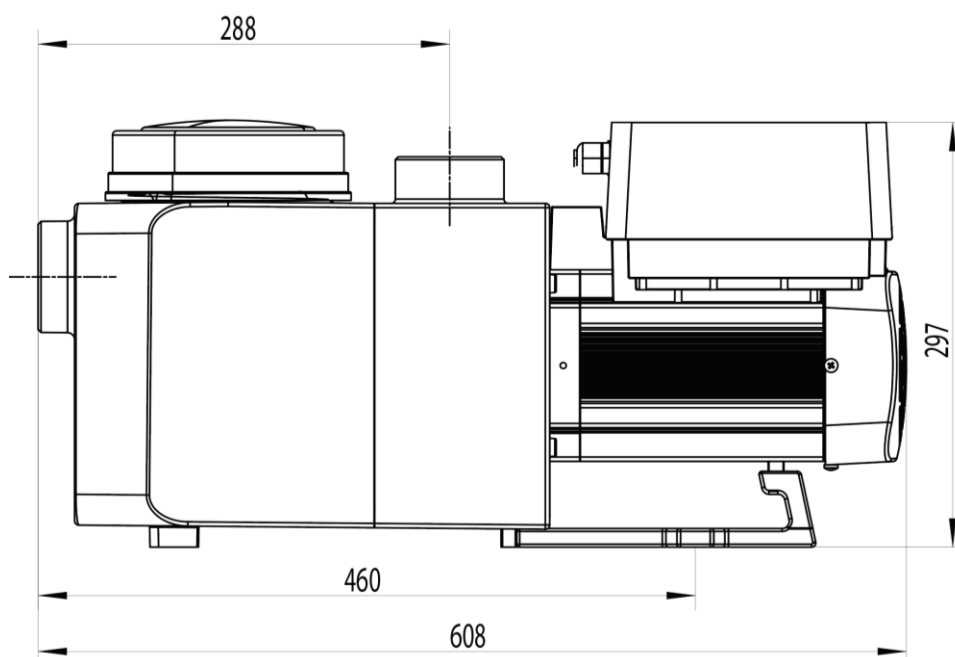

3.2: TECHNICAL DATA

Model	NPX1100	NPX1500	NPX2000	NPX2500
Input Power (kW)	0.80	1.05	1.40	1.75
Input Power (hp)	1.00	1.50	2.00	2.50
Voltage (V/Hz)	220-240 / 50/60			
Current (A)	3.5	5.3	6.5	8.0
Maximum Flow Rate (L/min)	408	438	488	678
Flow Rate @ 8m Head (L/min)	312	393	470	603
Flow Rate @ 10m Head (L/min)	243	333	420	543
Noise Level @ 30% Running Speed (dB)	33.0	35.4	36.3	37.4
Dimensions (mm)	690 x 270 x 340			
Net Weight (kg)	18	18	18	19
Gross Weight (kg)	20.5	20.5	20.5	21.5

3.3: OPERATING CONDITIONS

Ambient temperature	Indoor installation, pump is intended for continuous operation in the temperature range of -10 – 42°C
Water temperature	5°C – 50°C
Humidity	≤90% RH, (20°C ± 2°C)
Altitude	Do not exceed 1,000m above sea level
Installation	The pump can be installed max. 2m above water level
Protection	Class F, IP55

SECTION 4: INSTALLATION

4.1: PUMP LOCATION

1. Install the pump as close to the pool as possible. To reduce friction loss and improve efficiency, use short, direct suction and return piping.
2. To avoid direct sunshine, heat or rain, it is recommended to place the pump indoors or in the shade.
3. DO NOT install the pump in a damp or non-ventilated location. Keep pump and motor at least 150mm away from obstacles. Pump motors require free circulation of air for cooling.
4. The pump should be installed horizontally and fixed with screws to prevent unnecessary noise and vibration.
5. Your pump may have an earthing cable fitted to the motor. Australian standards currently do not require this cable to be connected.



4.2: PLUMBING THE POOL PUMP

1. For optimisation of the pool plumbing, it is recommended to use 50mm PVC pressure pipe. When installing the inlet and outlet fittings, use special sealant for PVC material.
2. The dimensions of the suction line should be the same or larger than the inlet line diameter, to avoid the pump sucking air, which will affect the pump's efficiency.
3. Plumbing on the suction side of the pump should be as short as possible.
4. For most installations we recommend installing a valve on both the pump suction and return lines, which is more convenient for routine maintenance. However, we also recommend that a valve, elbow, or tee installed on the suction line should be no closer to the front of the pump than seven times the suction line diameter.
5. The pump outlet piping system should be equipped with a check valve to prevent the pump from the impact of medium recirculation and water hammer.

4.3: VALVES & FITTINGS

1. Elbows should be no closer than 350mm to the inlet. Do not install 90° elbows directly into the pump inlet/outlet. Joints must be tight.
2. Flooded suction systems should have gate valves installed on suction and return line for maintenance. The suction gate valve should be no closer than seven times the suction pipe diameter as described in this section.
3. Use a check valve in the return line where there is a significant height between the return line and the outlet of the pump.
4. Be sure to install check valves when plumbing in parallel with other pumps. This helps prevent reverse rotation of the impeller and motor.

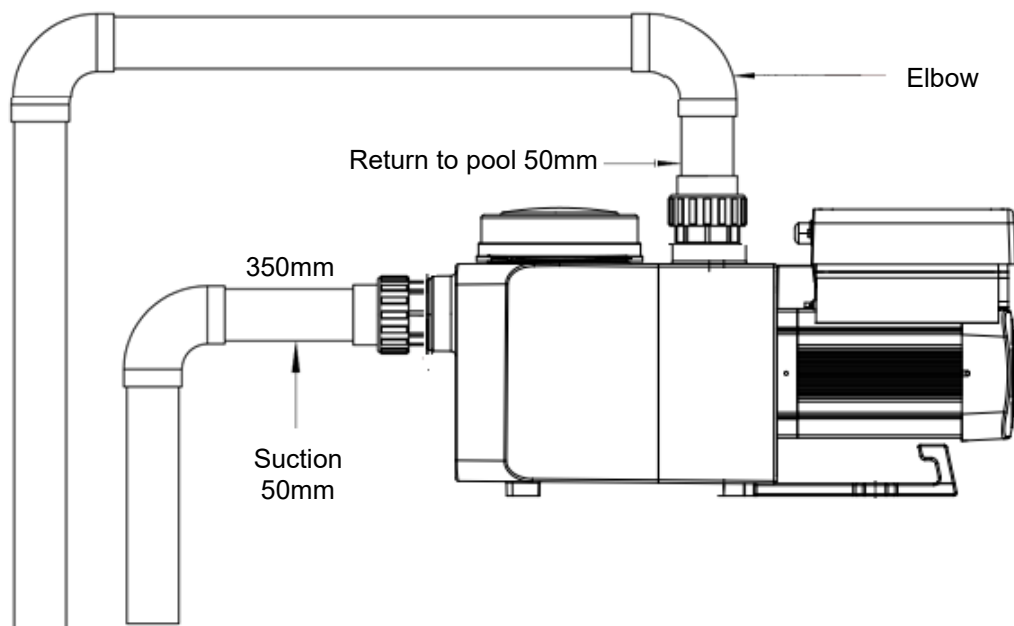

SECTION 5: TOUCHPAD OVERVIEW

	① Power consumption
	② Running capacity / Flow rate
	③ WIFI indicator
	④ Unit of flow
	⑤ Timer period
	⑥ Timer 1/2/3/4
	Backwash/unlock
	Up/down: to change the value (capacity/flow/time)
	Switch between Manual Inverter Mode and Auto Inverter Mode Manual Inverter Mode: The running capacity will be set manually between 30%-120% Auto Inverter Mode: The running capacity will be automatically adjusted between 30%-120% according to the preset flow rate. The default mode is Manual Inverter mode.
	Timer setting
On/off	

SECTION 6: START-UP AND OPERATION OF THE PUMP

Check all wirings and plumbing carefully before turning on the pool pump.

6.1: PRE-STARTUP INSPECTION

1. Ensure the pump shaft rotates freely.
2. Ensure the power supply voltage and frequency conform to the nameplate.
3. Facing the fan blade, the direction of motor rotation should be clockwise.
4. Check all wirings and plumbing are installed correctly.
5. Do not to run the pump without water.

6.2: STARTUP

1. Press and hold for more than 3 seconds to unlock the screen.
2. Press to start up the pump.

When the power is switched on, the screen will light up for 3 seconds, the device code will be displayed, and then it will enter the normal working state.

When the screen is locked, only the button will light up.

Press and hold for more than 3 seconds to unlock the screen.

The screen will automatically lock when there is no operation for more than 1 minute. The brightness of the screen will be reduced to 1/3 of the normal display.



Short press to wake up the screen and observe the relevant operating parameters.

6.3: SELF-PRIMING

Each time the pump is started, it will start self-priming.

1. The pump will start counting down from 1,500 seconds. When the system detects the pump is full of water, it will stop counting down and exit priming automatically.
2. To exit self-priming manually, press  for more than 3 seconds. Ensure the pump is full of water before exiting the self-priming process. The pump will enter the default Manual Inverter mode at the initial startup.

NOTE:

- The pump is delivered with self-priming enabled. Each time the pump restarts, it will perform self-priming automatically. To disable the default self-priming function, enter the parameter settings (see Section 6.13).
- If the default self-priming function is disabled, and the pump has not been used for an extended period of time, the water level in the pump basket may drop. To manually activate the self-priming function, press both   for 3 seconds. The adjustable period is from 600 seconds to 1,500 seconds.
- After the manual self-priming is completed, the pump will return to the previous running state. If the pump has entered the Auto Inverter mode previously, the pump will perform self-learning for 180 seconds to redefine the adjustable flow range after the manual self-priming.

6.4: SELF-CHECKING



After the pump has performed the self-priming process, the pump will recheck for 30 seconds again to make sure the self-priming is completed.

6.5: PUMP RUNNING

The pump will then run at 80% of the running capacity at the initial startup after the self-priming process.









6.6: BACKWASH

To start the backwash or fast re-circulation in any running state, press .

	Default	Setting Range
Time	180 sec	Press  or  to adjust from 0 to 1,500 seconds, in increments of 30 seconds.
Running Capacity	100%	80-100%. Adjust the backwash running capacity in the parameter settings (see section 6.13).

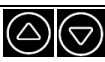
To exit the backwash mode, hold  for 3 seconds. The pump will return to the previous running state. If a speed limit is set, the running capacity of the backwash will not exceed the set speed limit (see Section 6.12).

6.7: MANUAL INVERTER MODE













	Hold  for more than 3 seconds to unlock the screen.
	Press  to start. The pump will run at 80% of the running capacity at the initial startup after the self-priming process.
	Press  or  to set the running capacity between 30%-120%, in increments of 5%.
	Press  to switch to Auto Inverter Mode.

NOTE:

- When the pipeline pressure is too high, to maintain an adequate flow rate, set the running capacity to 105%-120%. The pump will run at a higher speed but will not exceed the rated power of each model.
- If the pump has reached the rated power at 105% and users continue to increase the running capacity, the display will return to 105% when the motor speed is stabilised.

6.8: AUTO INVERTER MODE

In Auto Inverter Mode, the pump can automatically detect the system pressure and adjust the motor speed to reach the set flow.

	Hold  for more than 3 seconds to unlock the screen.
	Press  to switch from Manual Inverter Mode to Auto Inverter Mode.
	Press  or  to adjust the flow rate in 20L/min increments.
	The unit of the flow rate can be changed to L/min, IMP GPM (Imperial gallons per minute) or US GPM (U.S. gallons per minute, by pressing both   for 3 seconds.
	Press  to switch to Manual Inverter Mode.

6.9: SELF-LEARNING

When first switching to Auto Inverter Mode (manually, via external control or activating timer mode with flow rate setting), the system will perform the self-priming process (see Section 6.3) and will then run the self-learning process for 180 seconds. This will redefine the adjustable flow range of the pump by detecting the pipeline pressure.

The default adjustable flow range is as below:

Model	Default adjustable flow rate range
NPX1100	83L/min – 333L/min
NPX1500	83L/min – 417L/min
NPX2000	83L/min – 500L/min
NPX2500	133L/min – 583L/min

EXAMPLE: The default adjustable flow range of NPX1500 is 83L/min – 417L/min. After self-learning, the range may be redefined to 117L/min – 367L/min. If the set flow is beyond the current adjustable range, the actual achievable flow rate will be displayed after the motor speed is stabilised.











NOTE:





- After the first self-priming process, the pump will redefine the adjustable flow range. The pipeline pressure will be recorded by the system after the pump runs at the set flow/capacity for 5 minutes without other operations.
- During normal pump operation, if it is detected that the pipeline pressure changes beyond a certain range, the icon of % or L/min (or other flow units) symbol will flash for 5 minutes. If the change lasts for 5 minutes, the pump will perform a self-priming and self-learning process, and redefine the flow range accordingly.
- After the redefinition of the flow range, the pump will automatically adjust the running capacity to reach the set flow.
- Users can set the time interval to trigger the self-learning process automatically in the parameter settings (see Section 6.13) to ensure the accuracy of the flow rate.



6.10: TIMER MODE







The pump has 4 separate timers to program the pump's on/off and running capacity.

1	Press  to enter the timer settings.
2	Press  or  to set the local time. Press  to confirm and move to timer-1 setting.
3	Press  or  to choose the desired running periods, running capacity or flow rate. When % icon is flashing, press  to set the flow rate.
4	Press  and repeat above steps to set the other 3 timers.
5	Hold  for 3 seconds to save settings and activate timer mode.
6	Press  or  to check the 4 timers to ensure there are no invalid settings.

- When timer mode is activated, if the set time period contains the current time, the pump will start running according to the set running capacity or flow rate.
- If the set time period does not contain the current time, the timer indicator (1 or 2 or 3 or 4) that is about to start running will light up and flash, and **88:88 - 88:88** will display the corresponding time period, indicating a successful timer setting.
- To return to the previous setting during the timer setting, hold both   for 3 seconds.
- If 4 timers are not required, hold  for 3 seconds. The system will automatically save the current set value and activate the timer mode.
- To exit the timer mode, press .

6.11: SKIMMER MODE

Skimmer mode enables the pump to skim the water surface, preventing debris from accumulating, and providing users with a cleaner pool.

1. Hold  and  to enter the preset interface of the skimmer mode and press  or  to view the 3 presets. The selected preset will be activated after 8 seconds without operation.
2. To exit the skimmer mode without activating it, hold  and  in the preset interface.
3. While skimmer mode is running, the controller will show the parameter of the preset. Hold  to exit the skimmer duration each time. When the skimmer duration ends, the pump will return to its normal running state.

Preset	Skimmer cycle	Skimmer duration	Skimmer speed	Time period	Remark
1	1 hr	3 min	100%	7:00 – 21:00	Editable in parameter settings
2	1 hr	10 min	100%	7:00 – 21:00	Not editable
3	3 hr	3 min	80%	7:00 – 21:00	Not editable

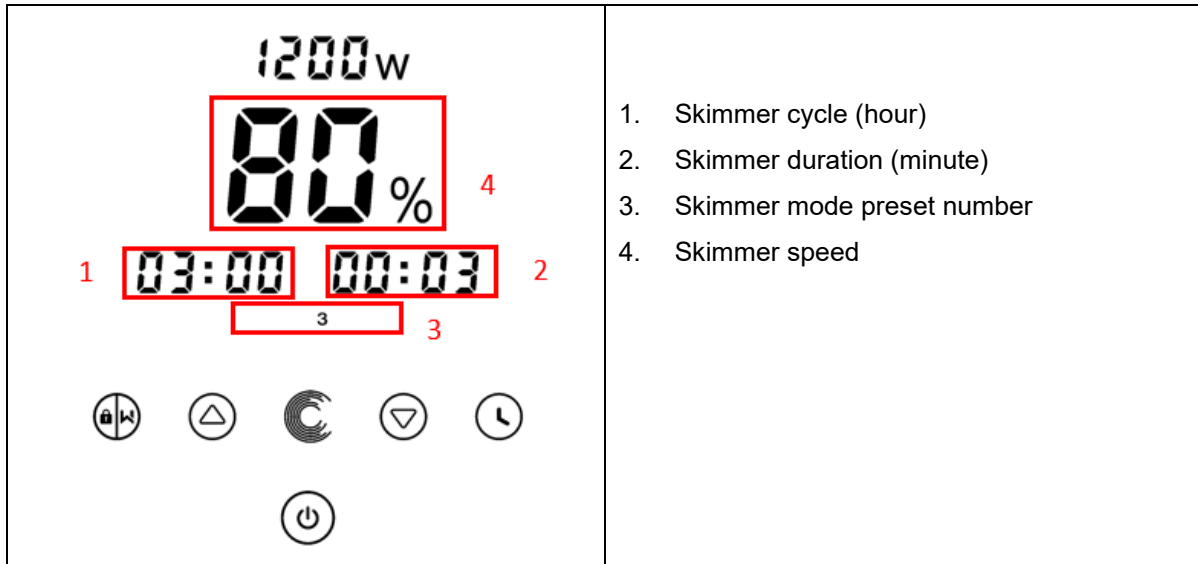

1. Skimmer cycle (hour)
2. Skimmer duration (minute)
3. Skimmer mode preset number
4. Skimmer speed

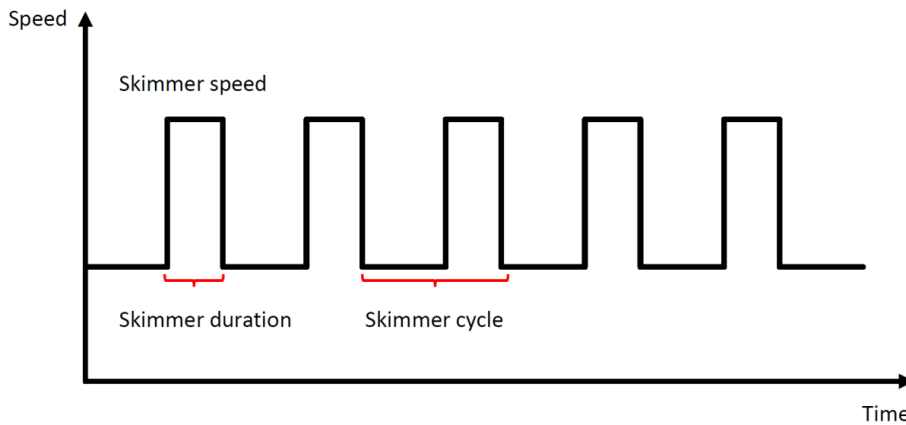

6.12: SPEED LIMIT









The speed limit of the running capacity can be set to meet the flow requirements of other equipment such as sand filters.

The speed limit of the running capacity can be set from 60% – 100% in the parameter settings. (see Section 6.13). 100% means no speed limit. The running capacity can be set from 30% – 120% under normal operation.

For optimal performance, the following modes/processes will not be limited by the speed limit:





- Self-priming at each start
- Manual self-priming
- Self-learning
- Auto Inverter mode
- Flow rate setting in the timer mode

6.13: PARAMETER SETTINGS

Restore factory setting	Under OFF mode, hold both   for 3 seconds
Check the software version	Under OFF mode, hold both   for 3 seconds
Enter the parameter settings	Under OFF mode, hold both   for 3 seconds to enter the parameter setting. Press  until you reach the desired parameter address. Adjust the settings by pressing  or  .

Parameter Address	Description	Default Setting	Setting Range
1	PIN3	100%	30-120%, in 5% increments
2	PIN2	80%	30-120%, in 5% increments
3	PIN1	40%	30-120%, in 5% increments
4	Backwash capacity	100%	80-100%, in 5% increments
5	Control mode of Analog Input	0	0: Current control 1: Voltage control
6	Enable or disable the self-priming at each start	25	25: enables 0: disables
7	Reserved	0	Not editable
8	System time	00:00	00:00 - 23:59
9	Preset 1 of the skimmer mode (skimmer cycle, skimmer duration, skimmer speed)	01:00 00:03 100%	Skimmer cycle: 1-24hr, in 1 hr increments Skimmer duration: 1-30min, in 1 min increments Skimmer speed: 30%-100%, in 5% increments
10	Time period of the preset 1 of the skimmer mode	7:00-21:00	Start time: 00:00-24:00 End time: 00:00-24:00
11	Speed limit	100%	60%-100%, in 5% increments 100% means no speed limit
12	RS485 address	170(0xAA)	160-190 (0xA0-0xBF), in qty 1 increments.
13	Time interval to trigger the self-learning automatically	0	0, 1, 3, 5, 7, 14, 21, 28 (day) "0" means no triggering of the self-learning automatically

EXAMPLE: How to Enable/Disable Self-Priming Function:

1. Enter parameter settings: Under off mode, hold both   for 3 seconds.
2. Select the self-priming parameter address: Press  until you reach Address 6.
3. Enable or disable self-priming at each startup: Adjust by pressing  or , 25= Enables, 0=Disables.

SECTION 7: EXTERNAL CONTROLLER (OPTIONAL)

An external controller can be used via the following contacts.

If more than one external control is enabled, the priority is: Digital Input > RS485 > Panel Control.

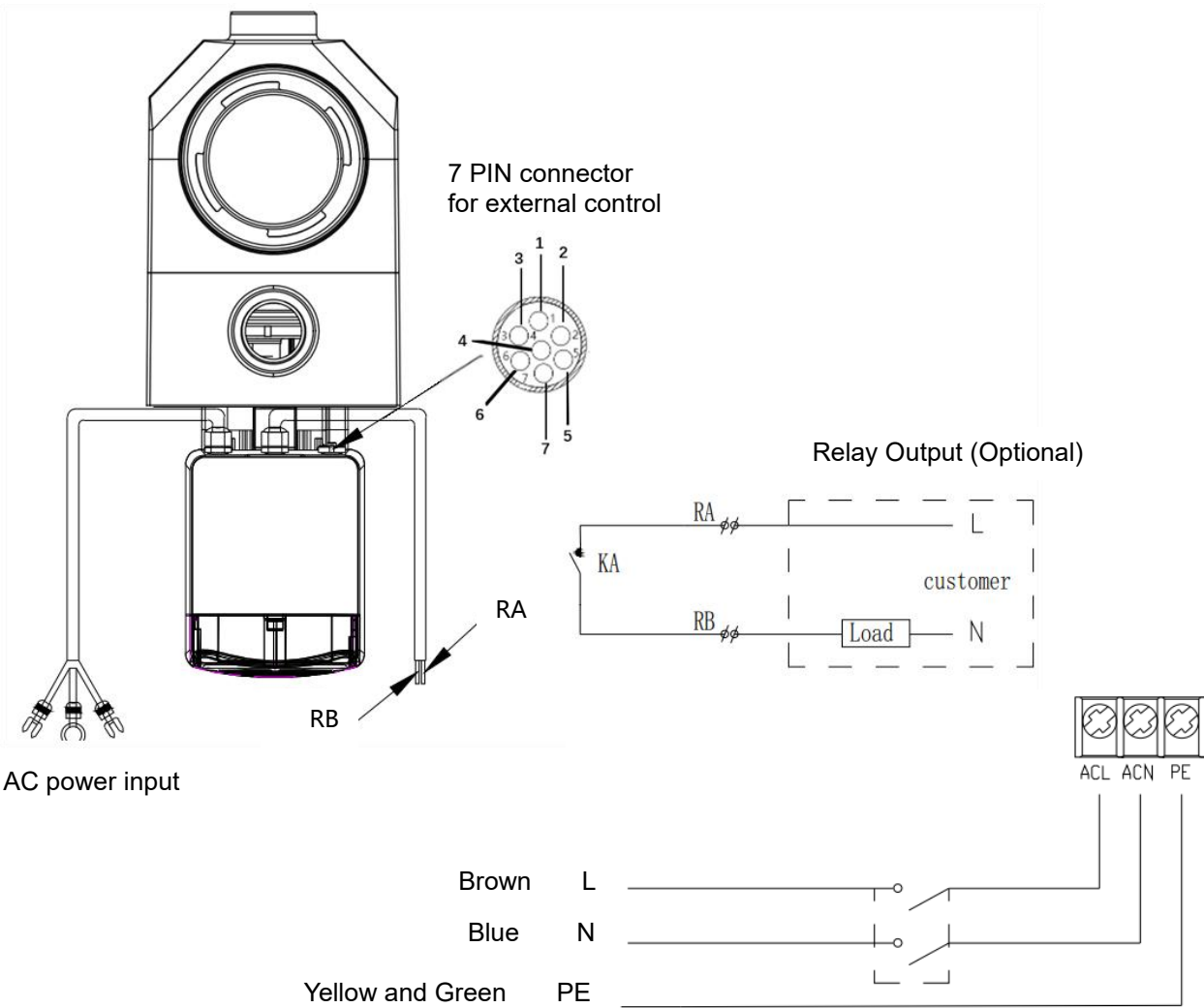
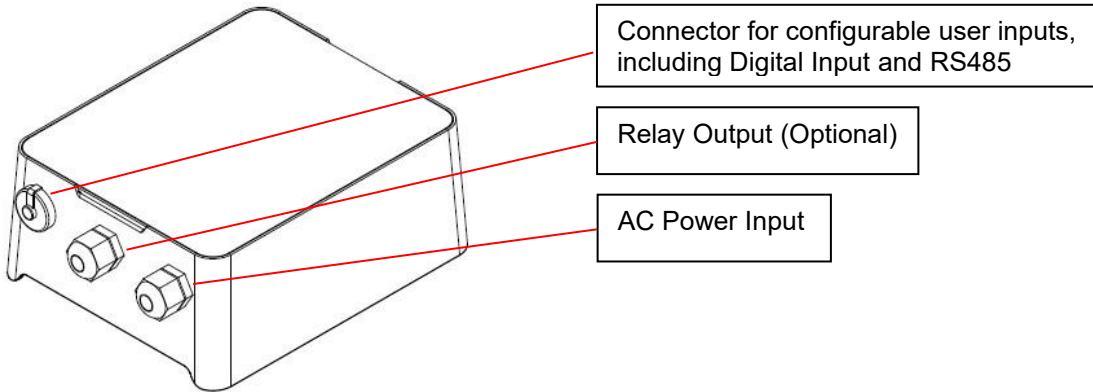

Name	Color	Description
PIN 1	Red	Digital Input 4
PIN 2	Black	Digital Input 3
PIN 3	White	Digital Input 2
PIN 4	Grey	Digital Input 1
PIN 5	Yellow	Digital Ground
PIN 6	Green	RS485 A
PIN 7	Brown	RS485 B



1. Digital Input: The running capacity is determined by the state of digital input.
 - When PIN4 connects with PIN5, the pump will be mandatory to stop; if disconnected, the digital controller will be invalid.
 - When PIN3 connects with PIN5, the pump will be mandatory to run at 100%; if disconnected, the control priority will be back on panel control.
 - When PIN2 connects with PIN5, the pump will be mandatory to run at 80%; if disconnected, the control priority will be back on panel control.
 - When PIN1 connects with PIN5, the pump will be mandatory to run at 40%; if disconnected, the control priority will be back on panel control.
 - The capacity of inputs (PIN1/PIN2/PIN3) could be modified according to the parameter setting.
2. RS485
 - To connect with PIN6 and PIN7, the pump could be controlled via Modbus 485 communication protocol.

SECTION 8: MAINTENANCE

Empty the pump basket frequently. The basket should be inspected through the transparent lid and emptied when there is debris inside. The following instructions should be followed:

1. Disconnect the power supply.
2. Unscrew the pump lid anti-clockwise and remove.
3. Lift up the pump basket.
4. Empty the debris from the basket and rinse out the debris if necessary.
NOTE: Do not knock the plastic basket on a hard surface as it will cause damage.
5. Inspect the basket for signs of damage and replace if required.
6. Check the Pump Lid O-Ring for stretching, tears, cracks or any other damage.
7. Replace the pump lid, hand tightening is sufficient.

NOTE: Periodically inspecting and cleaning the pump basket will help prolong the life of your pump.

SECTION 9: PROTECTION MANAGEMENT

9.1: High-Temperature Warning and Speed Reduction

In Auto Inverter Mode, Manual Inverter Mode and Timer Mode (except backwash/self-priming), when the module temperature reaches the high-temperature warning trigger threshold (81°C), the pump will enter the high-temperature warning state. When the temperature drops to the high-temperature warning release threshold (78°C), the high-temperature warning state is released. The display area alternately displays AL01 and the running speed or flow.

If AL01 is displayed for the first time, the running capacity will be automatically reduced as below:

1. If current operating capacity is higher than 100%, the running capacity will be automatically reduced to 85%.
2. If current operating capacity is higher than 85%, the running capacity will be automatically reduced by 15%.
3. If current operating capacity is higher than 70%, the running capacity will be automatically reduced by 10%.
4. If current operating capacity is lower than 70%, the running capacity will be automatically reduced by 5%.

9.2: Under-Voltage Protection

When the device detects that the input voltage is less than 197V, the device will limit the current running speed. The display area alternately displays AL02 and running speed or flow.

1. When input voltage is less than or equal to 180V, the running capacity will be limited to 70%.
2. When the input voltage range is within 180V - 190V, the running capacity will be limited to 75%.
3. When the input voltage range is within 190V - 197V, the running capacity will be limited to 85%.



SECTION 10: WIFI OPERATION

10.1: App Download and Account Registration

1. Download the InverFlow App, available on iOS and Android.



2. Register/sign up via email or 3rd party application.

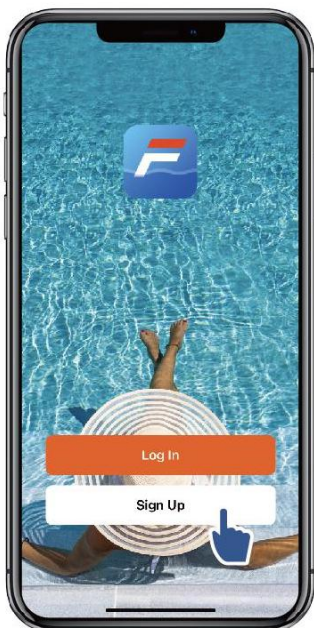

Email:

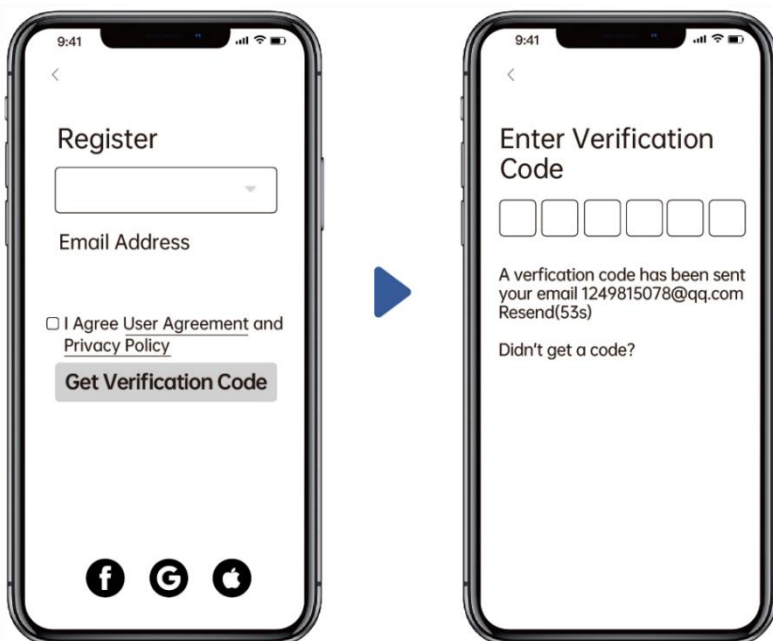

3rd party application:

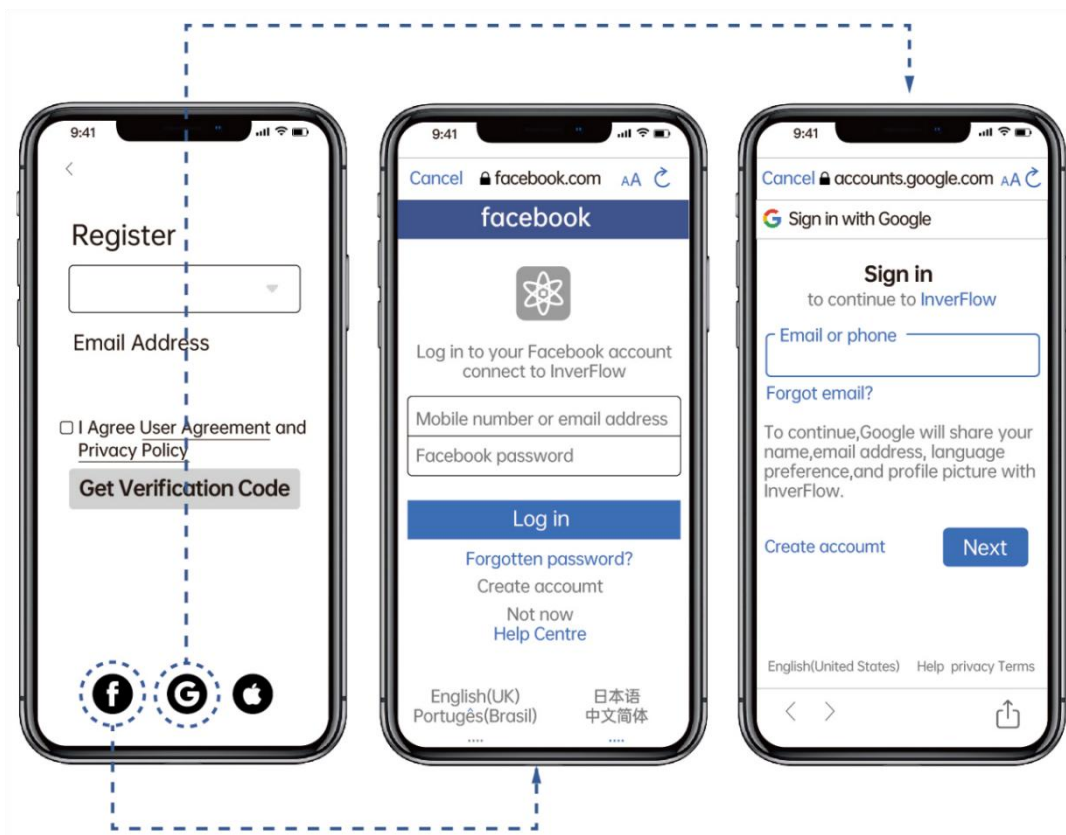

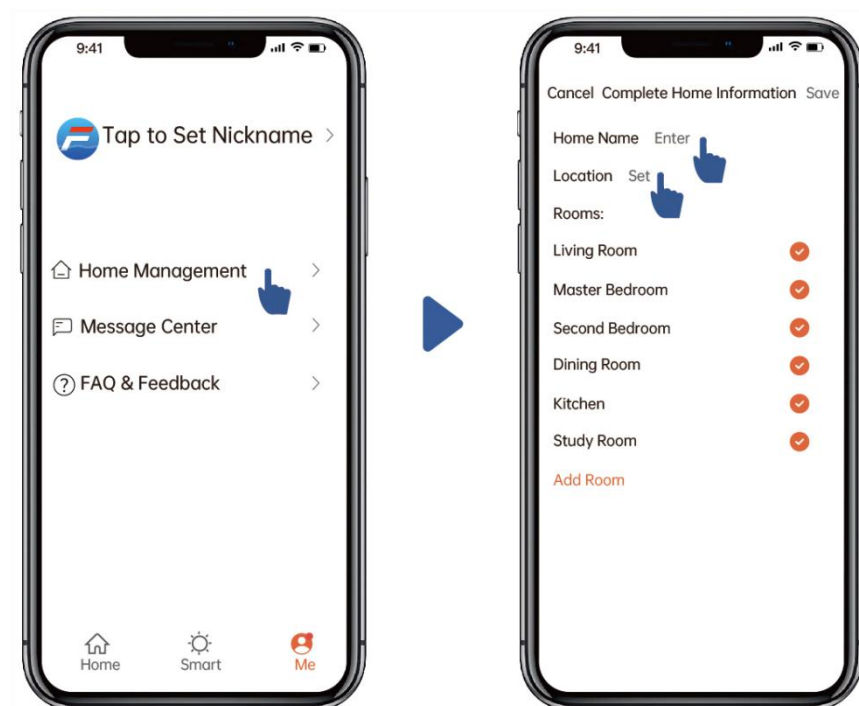

10.2: Create a Home

Set a Home Name and choose the location of the device. It is recommended to set the location so the weather can be shown in the App for your convenience.





10.3: App Pairing Via WiFi and Bluetooth

Network requirements: 2.4GHz; 2.4Ghz and 5GHz into one SSID; but no separate 5GHz network.

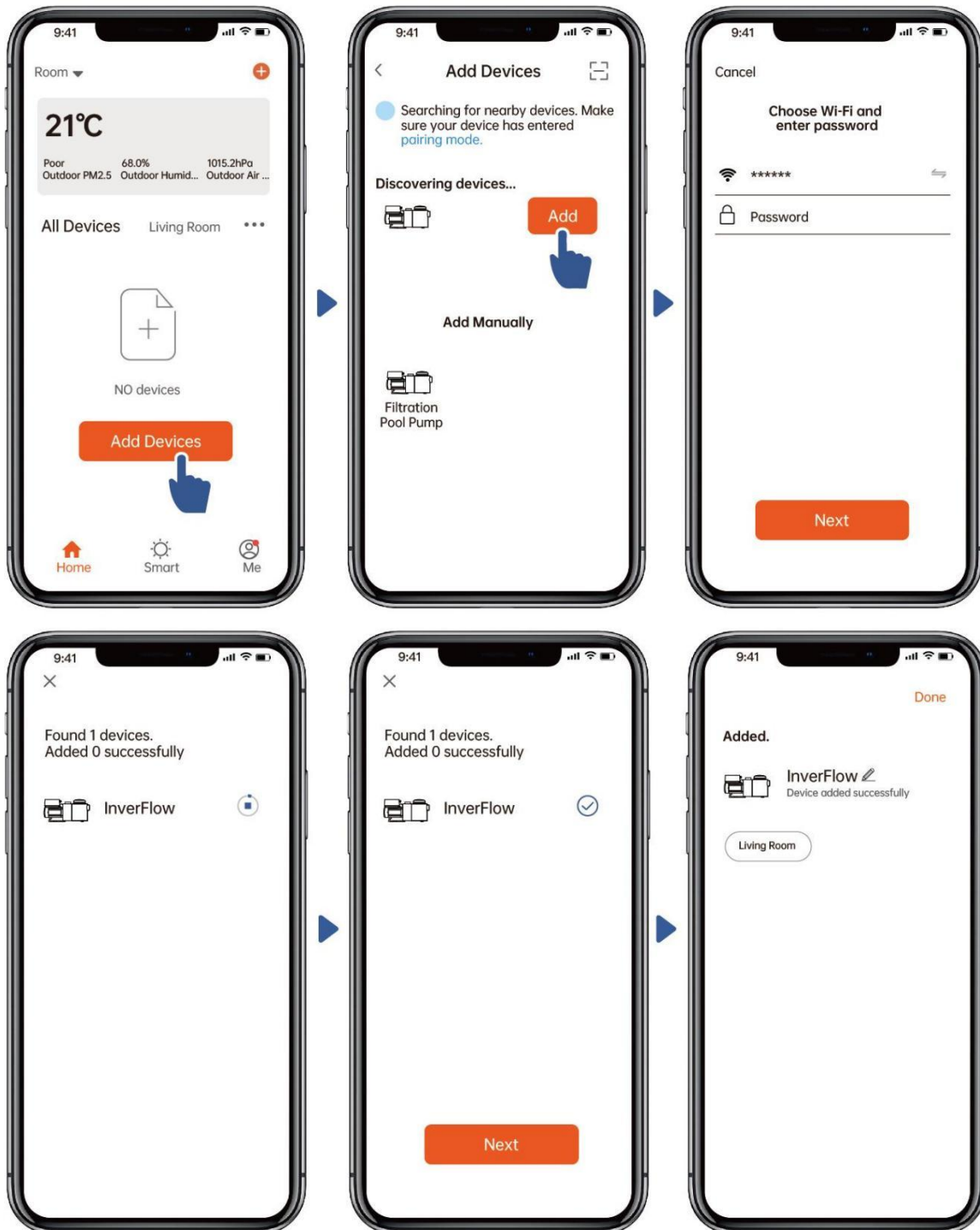
1. Ensure the pump is on before you start App pairing.
2. Ensure your phone is connected to WiFi and your Bluetooth is on.
3. On the pump, press  for 3 seconds until you hear a “Beep” to unlock the screen. Press  for 5 seconds until you hear a “Beep” and then release.  will flash.
4. Click “Add Device”, and then follow the instructions to pair device.



10.4: App Pairing Via WiFi Only

1. Ensure the pump is on before you start App pairing.
2. Ensure your phone is connected to WiFi.
3. On the pump, press  for 3 seconds until you hear a “Beep” to unlock the screen. Press  for 5 seconds until you hear a “Beep” and then release.  will flash.
4. Click “Add Device”, and then follow the instructions to pair device.

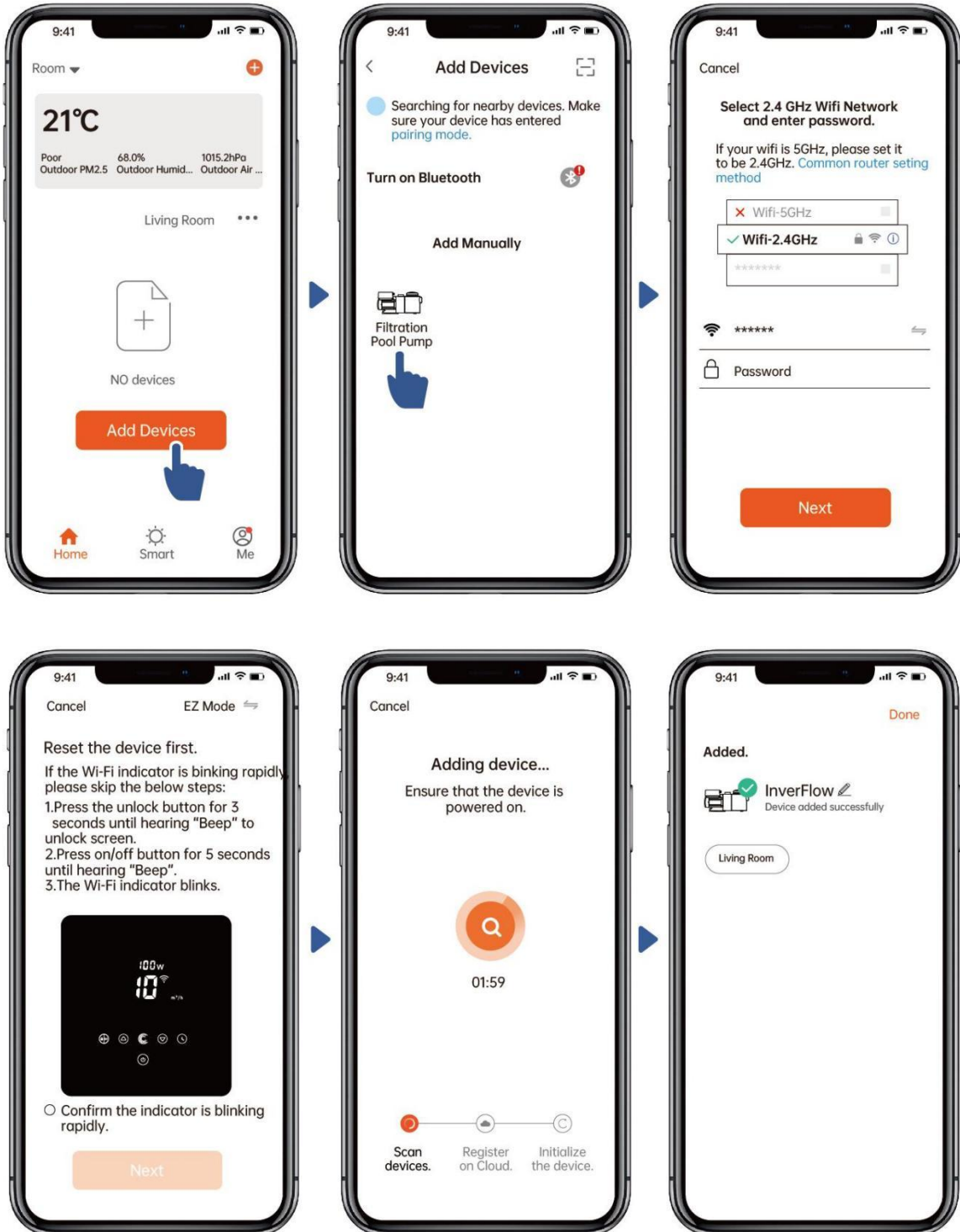

10.5: App Operation – Auto Inverter Mode

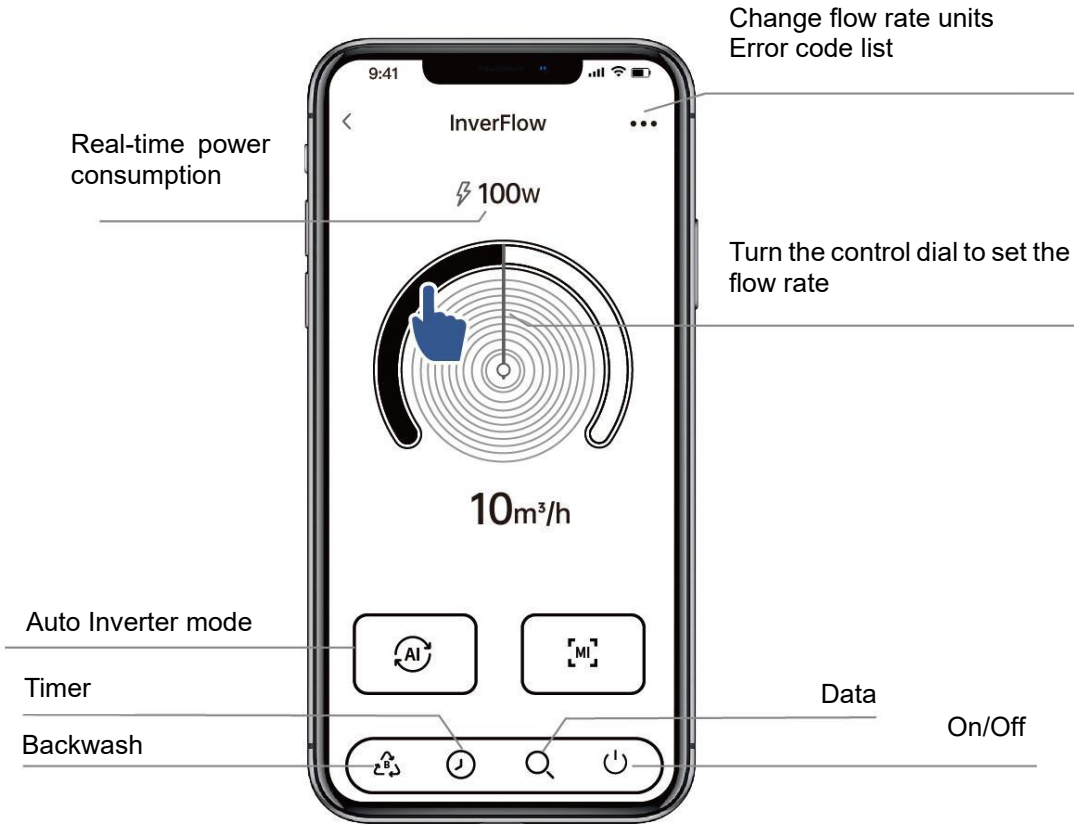

10.6: App Operation – Manual Inverter Mode

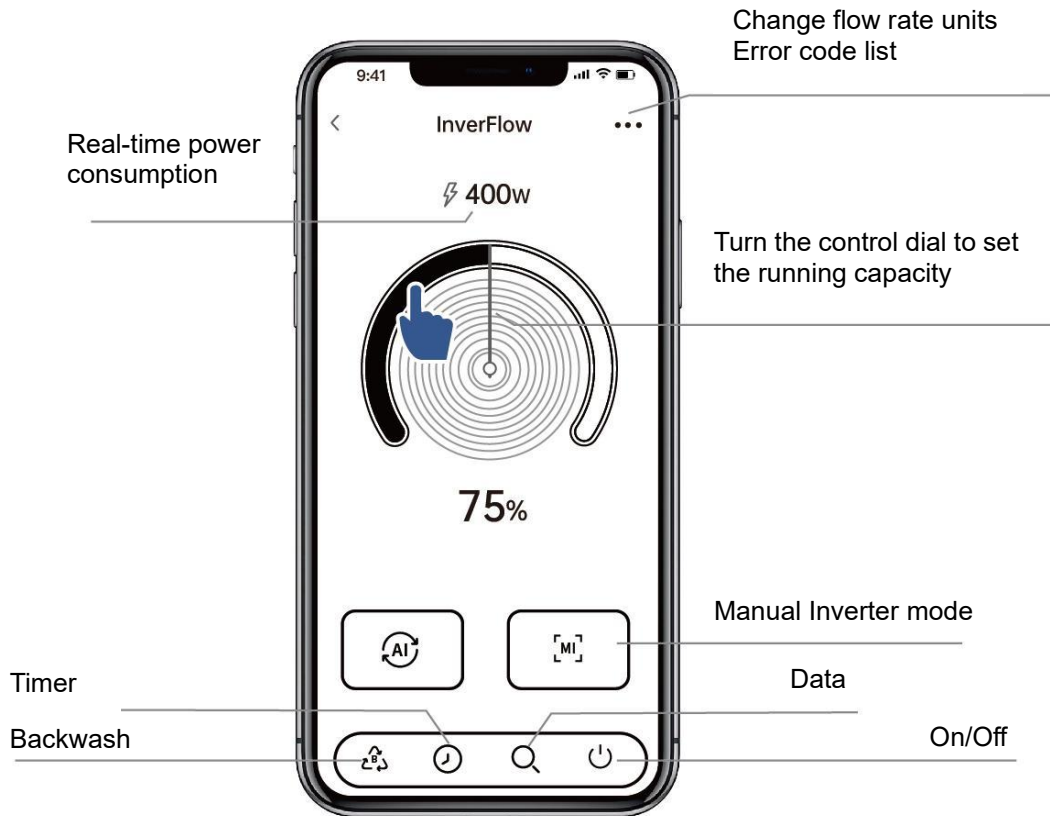

10.7: App Operation – Setting the Timer

- Time variance is $\pm 30s$.
- In order to avoid overlapping timing points, it is recommended that there is at least a 2 minute time gap between the end of the first timer and the start of the next timer.

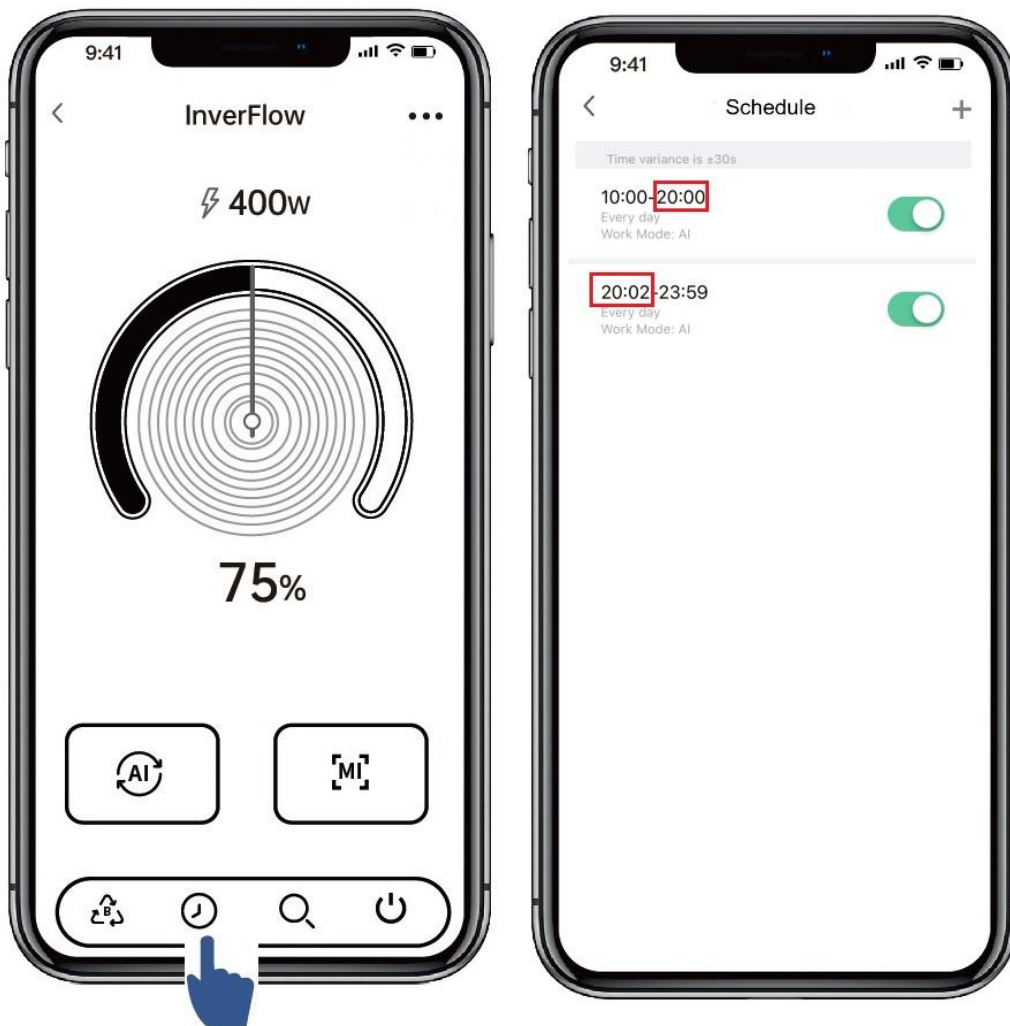

10.8: App Operation – Sharing Devices with Family Members

After pairing, if your family members also want to control the device, please let your family members register on the InverFlow App first, and then the administrator can operate as below:



NOTE:

- The weather forecast shown in the diagrams are for reference only.
- The power consumption data shown in the diagrams are for reference only, as it may be affected by network problems and imprecision of the calculation.
- The InverFlow App is subject to updates without notice.

SECTION 11: TROUBLESHOOTING

Problem	Possible causes and solution
Pump does not start	<ul style="list-style-type: none"> • Power supply fault, disconnected or defective wiring. • Fuses blown or thermal overload open. • Check the rotation of the motor shaft for free movement and lack of obstruction. • If pump has been unused for an extended period of time, unplug the power supply and manually rotate the motor's rear shaft a few times with a screwdriver.
Pump does not prime	<ul style="list-style-type: none"> • Empty pump basket. Make sure the pump housing is filled with water and the Pump Lid O-Ring is clean. • Loose connections on the suction side. • Pump basket or skimmer basket loaded with debris. • Suction side clogged. • Distance between pump inlet and water level is higher than 2m, the installation height of pump should be lowered.
Low water flow	<ul style="list-style-type: none"> • Pump does not prime. • Air entering suction piping. • Pump basket full of debris. • Inadequate water level in pool.
Pump being noisy	<ul style="list-style-type: none"> • Air leak in suction piping, cavitation caused by restricted or undersized suction line or leak at any joint, low water level in pool, and unrestricted discharge return lines. • Vibration caused by improper installation, etc. • Damaged motor bearing or impeller (contact your supplier for repair).

When the device detects a failure, it will stop automatically and display an error code. After stopping for 15 seconds, check if the failure is cleared. If cleared, the pump will resume working.

Item	Error Code	Details	
		Description	Process
1	E001	Description	Abnormal input voltage: the power supply voltage is out of the range of 165V to 275V.
		Process	The pump will stop automatically for 15 sec and resume working if it detects the power supply voltage is within the range.
2	E002	Description	Output over current: The peak current of the pump is higher than the protection current.
		Process	The pump will stop automatically for 15 sec and then resume working. If this occurs 3 times, the pump will shut down and will need to be checked and restarted manually.
3	E101	Description	Heat sink overheat: The heat sink temperature reaches 91°C for 10 sec.
		Process	The pump will stop automatically for 30 sec and resume working if it detects the heat sink temperature is less than 81°C.
4	E102	Description	Heat sink sensor error: The heat sink sensor detects an open or short circuit.
		Process	The pump will stop automatically for 15 sec and resume working if it detects the heat sink sensor is not open or short circuit.



Item	Error Code	Details	
5	E103	Description	Master driver board error: The master driver board is faulty.
		Process	Same process as E002.
6	E104	Description	Phase-deficient protection: Motor cables are not plugged into the master drive board.
		Process	Same process as E002.
7	E105	Description	AC current sampling circuit failure: When the pump power is off, the bias voltage of the sampling circuit is out of the range of 2.4V to 2.6V.
		Process	The pump needs to be powered off and restarted manually.
8	E106	Description	DC abnormal voltage: The DC voltage is out of the range of 210V to 420V.
		Process	Same process as E002.
9	E107	Description	PFC protection: PFC protection occurs on the master driver board.
		Process	Same process as E002.
10	E108	Description	Motor power overload: Motor power exceeds the rated power by 1.2 times.
		Process	Same process as E002.
11	E201	Description	Circuit board error: When the pump power is off, the bias voltage of the sampling circuit is out of the range of 2.4V to 2.6V.
		Process	The pump needs to be powered off and restarted manually.
12	E203	Description	RTC time reading error: Reading and writing of the timer clock information is incorrect.
		Process	The pump needs to be powered off and restarted manually.
13	E204	Description	Display Board EEPROM reading failure: Reading and writing of the display board EEPROM information is incorrect.
		Process	The pump needs to be powered off and restarted manually.
14	E205	Description	Communication Error: The communication between display board and master driver board fails for 15 sec.
		Process	The pump will stop automatically for 15 sec and resume working if it detects the communication between display board and master driver board lasts 1 sec.
15	E207	Description	No water protection: The pump does not have enough water.
		Process	Stop the pump manually, fill up the pump with water and restart it. If this occurs 2 times, the pump will shut down and will need to be checked manually.
16	E208	Description	Pressure sensor failure: The pressure sensor is open or short circuit.
		Process	The pump needs to be powered off and restarted manually.
17	E209	Description	Loss of prime: The pump cannot self-prime due to reasons such as exceeding the suction range, or the pipeline is too complicated.
		Process	Check the pump or pipeline that there is no leakage, and then fill up the pump with water and restart it.

SECTION 12: DISPOSAL

When disposing of the product, please sort the waste products as electrical or electronic product waste, or hand it over to the local waste collection system.

The separate collection and recycling of waste equipment at the time of disposal will help ensure that it is recycled in a manner that protects human health and the environment. Contact your local authority for information on where you can drop off your water pump for recycling.

SECTION 13: SCHEMATICS

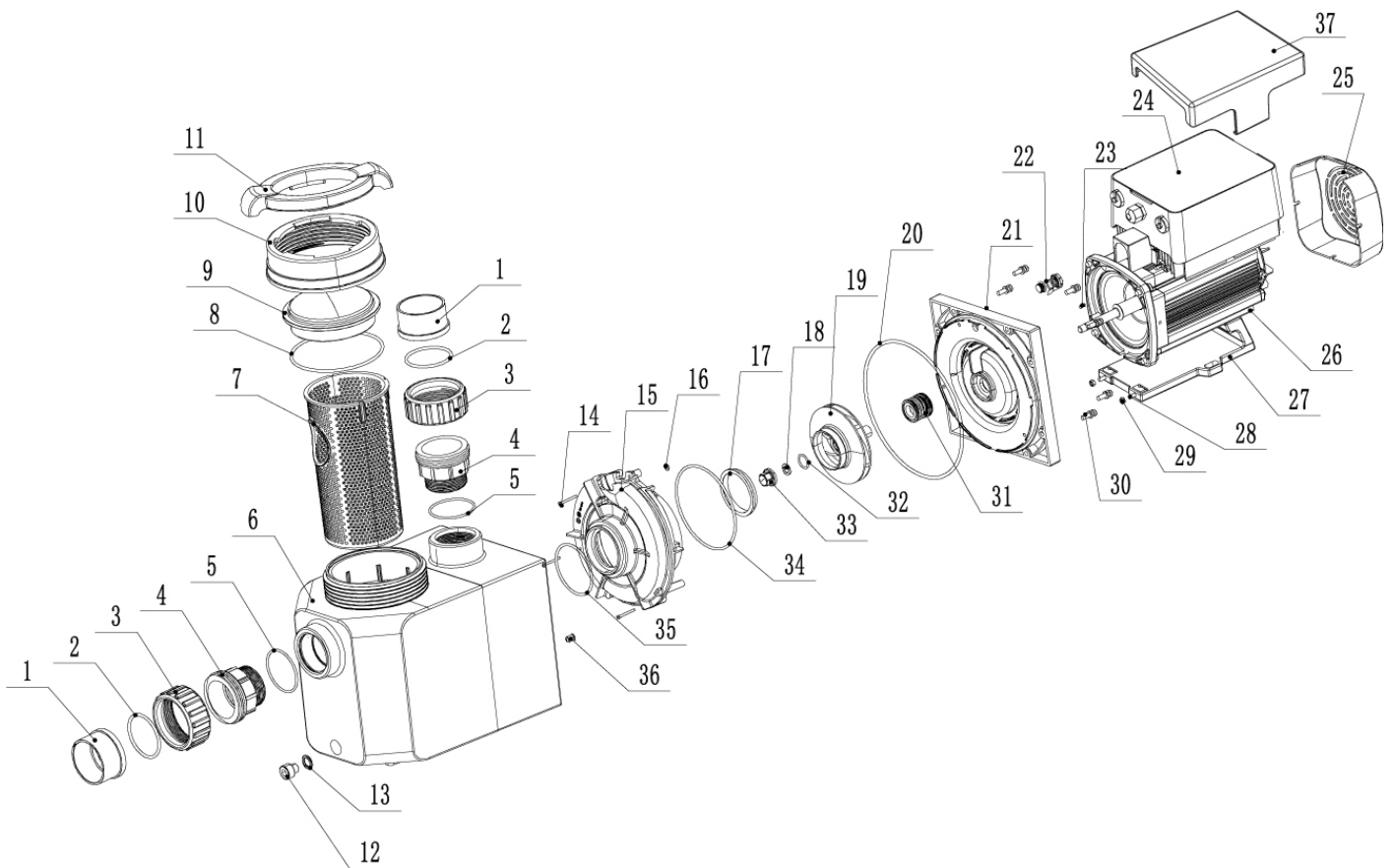

Ref #	Stock Code	DESCRIPTION	QTY
1, 2 & 3	NPEP001	Union Tail, Union O-Ring & Union Nut	Set
4	NPXP002	Threaded Tail	2
5	OR955M	Threaded Tail O-Ring	2
6	NPXP063	Pump Body	1
7	SBN3	Pump Basket	1
8	OR956M	Pump Lid O-Ring	1
9	LD017	Pump Lid (Transparent)	1
10	NPXP004	Lid Locking Ring	1
11	NPXP005	Lid Loosening Tool	1
12	NPXP006	Drain Plug	1
13	OR952M	Drain Plug O-Ring	1
14	NPXP007	Volute Screw	3
15	NPXP008	Volute suits NPX1100, NPX1500 & NPX2000	1
16	OR957M	Volute O-Ring Small	1
17	TBA	Turnable Retaining Ring	1
18	TBA	Impeller Spring Washer	1
19	NPEP031	Impeller suits NPX1100, NPX1500 & NPX2000	1
19	NPEP032	Impeller suits NPX2500	1
20	GAS681	Pump Body Gasket	1
21	NPXP012	Backplate	1
22	NPXP013	Pressure Sensor suits NPX1100, NPX1500 & NPX2000	1
22	NPXP014	Pressure Sensor suits NPX2500	1
23	TBA	Parallel Key	3
24	NPXP050	Inverter Controller w/ WiFi & Relay suits NPX1100	1
24	NPXP051	Inverter Controller w/ WiFi & Relay suits NPX1500	1
24	NPXP052	Inverter Controller w/ WiFi & Relay suits NPX2000	1
24	NPXP053	Inverter Controller w/ WiFi & Relay suits NPX2500	1
25	NPXP016	Fan Cover	1
26	NPXP060	Pump Motor suits NPX1100, NPX1500 & NPX2000	1
26	NPXP061	Pump Motor suits NPX2500	1
27	NPXP017	Motor Base	1
28	TBA	Motor Base Plate Screw	2
29	TBA	Motor Base Plate Nut	2
30	TBA	Backplate Screw	8
31	MC30	Mechanical Seal	1
32	OR961M	Impeller O-Ring	1
33	TBA	Impeller Nut	1
34	OR958M	Rear Volute O-Ring	1
35	OR959M	Front Volute O-Ring	1
36	TBA	Rubber Plug	2
37	NPXP064	Inverter Controller Cover	1
-	NPXP024	Motor Termination Set	1
-	NPXP025	Controller Housing w/ Tempered Glass suits NPX1100, NPX1500 & NPX2000	1
-	NPXP026	Controller Housing w/ Tempered Glass suits NPX2500	1
-	NPXP027	Display Board suits NPX1100, NPX1500 & NPX2000	1
-	NPXP030	Display Board suits NPX2500	1
-	NPXP031	Fan suits NPX1100, NPX1500 & NPX2000	1
-	NPXP032	Fan suits NPX2500	1



SECTION 14: WARRANTY AND PRODUCT REGISTRATION

Please register your product online at www.poolpro.com.au/product-registration.

- The limited warranty for the Neptune X-Pro Inverter Pool Pump (models NPX1100, NPX1500, NPX2000 & NPX2500) covers manufacturer's defects in materials and workmanship for 5 years on all parts and labour. If the pool pump is installed in a commercial setting, the warranty period is 1 year on all parts and labour.
- The warranty is only valid for the original purchaser and is non-transferable.
- Adverse operating conditions beyond the control of the manufacturer such as improper voltage, excessive ambient temperature or any condition that adversely affects the performance of the equipment will render this warranty null and void.
- Defective equipment must be returned to the authorised dealer as soon as the purchaser becomes aware of the defect and all transport costs must be prepaid.
- Neither the manufacturer nor the authorised dealer shall be responsible for any goods damaged in transit.
- Any liability of the manufacturer pursuant to the Trade Practices Act 1974, as amended for a breach of a condition or warranty shall be limited to replacing or acquiring the equipment (or part thereof) where the same has been supplied.
- The maximum liability incurred by the manufacturer shall not in any case exceed the contract price for the equipment or the product parts or components thereof claimed to be defective. Further, the manufacturer shall not be liable for any loss, damage or delay directly or indirectly caused by any malfunction of or defect of or failure of the equipment other than as expressly provided in this warranty.
- The manufacturer and authorised dealer will not be held liable for damage caused to the pool and surrounding areas.
- Keep your original purchase invoice and serial number in a safe place.

Warranty is void under the following circumstances:

- Incorrect operation of the unit by not following correct instructions.
- Foreign matter blocking impeller or restricting water flow.
- Incorrect installation, including inadequate ventilation.
- Improper maintenance and balancing of pool water.
- Damage caused to the pool pump due to misuse or damage caused by any other means than manufacturer defect.
- If the pool pump is repaired or serviced by an unauthorised dealer or serviceman.
- If a fault occurs in the operation of the pool pump by using non-genuine parts/accessories.
- If the pool pump has been misused, neglected, damaged or altered in any way, including running the pump without sufficient water flow, lightning strikes, flooding or incorrect power supply.
- General wear and tear of consumable products.

To submit a warranty request, visit www.poolpro.com.au/serviceclaim

